

The DPK series is perfect for operations requiring mobile pumpout services.



## DPK20E

Low cost mobile pump on dock cart, prewired for standard 120V power outlet.



## DPK125

Gas powered mobile pump suitable for trailer, truck or boat mounting.

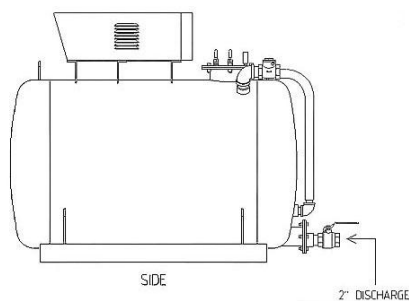

## DPK240

Higher capacity gas powered mobile pump. Suitable for trailer, truck or boat mounting.

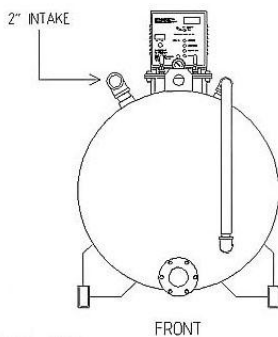

## DPK240E

Higher capacity mobile pump. Prewired for standard 120V power outlet. Suitable for trailer, truck or boat mounting.

Waubashene, Ontario  
CANADA

**Tel:** 705.538.1495

**Toll Free:** 800.663.1624  
(Canada & US Only)

**Fax:** 705.538.1776

**www.wmwpump.com**

STANDARD EQUIPMENT	DPK20E	DPK125	DPK240	DPK240E
Motor	¼ Hp electric	3 Hp Gas (Honda)	3 Hp gas (Honda)	¾ Hp electric
Tank	25 US Gal. (94l)	115 US Gal. (435l)	220 US Gal. (832l)	220 US Gal. (832l)
Connections (Intake & Discharge)	1 ½" NPT	2" NPT	2" NPT	2" NPT
Finish	Blue Metallic Top Hot Dipped Galv. Cycle Tank	White or Blue Metallic	Hot Dipped Galv. Cycle Tank	White or Blue Metallic Top Hot Dipped Galv. Cycle Tank
Accessories (Incl.)	25 ft Intake Hose Assembly	33 ft Intake Hose Assembly	33 ft Intake Hose Assembly	33 ft Intake Hose Assembly
	2 Sizes Deck Adapters	2 Sizes Deck Adapters	2 Sizes Deck Adapters	2 Sizes Deck Adapters
	Universal Deck Adapter	Universal Deck Adapter	Universal Deck Adapter	Universal Deck Adapter
	Potty Wand	Potty Wand	Potty Wand	Potty Wand

### PERFORMANCE SPECIFICATIONS

Max. Suction Lift (recommended)	20 ft (6 m)	20 ft (6 m)	20 ft (6 m)	20 ft (6 m)
Max. Suction Distance (recommended)	100 ft (30 m)	500 ft (150 m)	500 ft (150 m)	250 ft (75 m)
Max. Suction Performance*	20 GPM (75 l/min)	90 GPM (340 l/min)	90 GPM (340 l/min)	50 GPM (190 l/min)
Max. Discharge Head	30 ft (9 m)	30 ft (9 m)	30 ft (9 m)	30 ft (9 m)
Max. Discharge Distance (recommended)	250 ft (75 m)	1000 ft (300 m)	1000 ft (300 m)	500 ft (150 m)
No. of Boats Serviceable at Same Time	1	2	2	1

### DIMENSIONS

Width	27" (69 cm)	30" (76 cm)	36" (92 cm)	36" (92 cm)
Length	70" (178 cm)	60" (153 cm)	72" (183 cm)	72" (183 cm)
Height	38" (97 cm)	56" (143 cm)	60" (153 cm)	53" (135 cm)
Tank Diameter	14" (36 cm)	30" (76 cm)	36" (92 cm)	36" (92 cm)
Empty Weight	200 lbs (91 kg)	440 lbs (200 kg)	800 lbs (365 kg)	800 lbs (365 kg)
Full Weight	425 lbs (193 kg)	1440 lbs (655 kg)	2700 lbs (1228 kg)	2700 lbs (1228 kg)
Intake Port	1 ½"	2"	2"	2"
Discharge Port	1 ½"	2"	2"	2"

\* performance (in US gallons/minute) through full intake port @ 0 ft vertical lift, 1725 rpm

### Standard Features

- Auto shutoff when full
- Power discharge – no separate pump to empty cycle tank required
- Easy single switch operation
- PVC sight tube to monitor fluid level (DPK125, DPK240 and DPK240E)
- Indicator lights to monitor tank status (DPK20E and DPK240E)

### Optional Equipment Available

- Cycle tank galvanizing and dual coating options available
- Hose hangers on tank
- Trailer with light and hydraulic surge brake packages
- Electronic level indicator (DPK125, DPK240 and DPK240E)
- 5 Hp Honda gas power with electric start
- Single hand operated suction nozzle

All WMW control boxes have been UL approved.

Specifications subject to change without notice.



Waubashene, Ontario  
CANADA

Tel: 705.538.1495

Toll Free: 800.663.1624  
(Canada & US Only)

Fax: 705.538.1776

www.wmwpump.com